

Spirovent® Dirt
36" High Velocity Air Eliminator and Dirt Separator

Job Name:
Engineer:
Contractor:
Representative:

Tag	Model	Flow	Size	Location

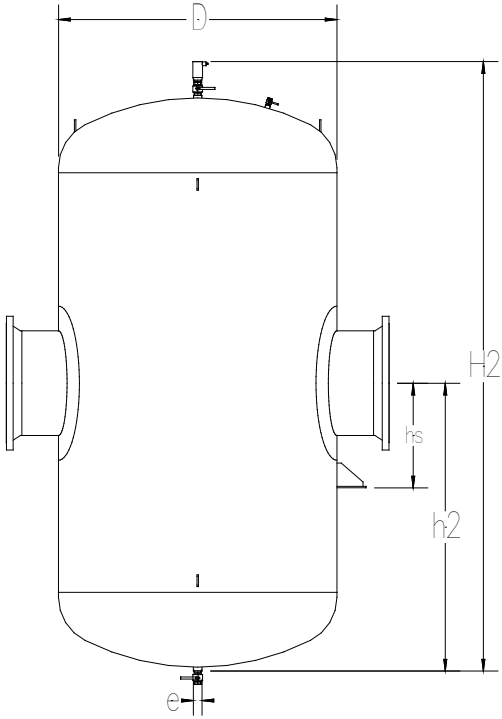

Specifications:

Shell	Steel
Vent Head	Brass
Float	Non-Ferrous
Seal	Viton
O Ring	Viton
Skim Valve	Brass
Coalescing Medium	Copper
Ball Valve	Brass
Max. Working Pressure	150 psig
Max. Operating Temperature	270°F

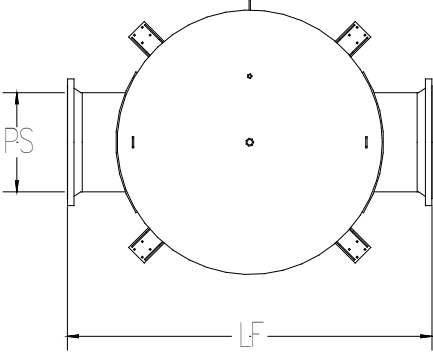

Pipe Size	36"
D (inches)	96
H2 (inches)	204
h2 (inches)	96
LF (inches)	132
hs (inches)	36
e (inches)	2
Dry Weight (lbs)	16,000
Volume (gallons)	5,420
Max. Flow (gpm)	29,600
Model	VHT----FA 3600

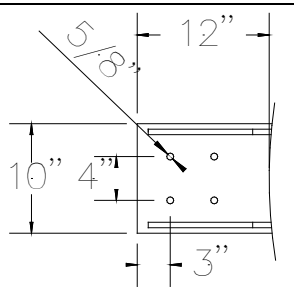

Bracket Detail

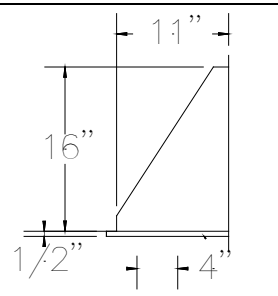

Bracket Detail

(Dimensions for reference only)

Flanged ASME Section VIII, Division 1 Stamped and Registered