

Spirovent® Dirt Microbubble™ Eliminator, Dirt Separator,

Job Name:
Engineer:
Contractor:
Representative:

Tag	Model	Flow	Size	Location

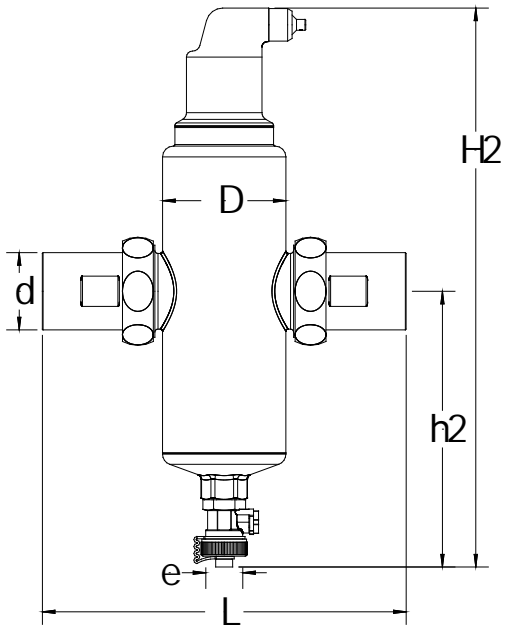

Specifications:

Body	Brass
Vent Head	Brass
Float	Non-Ferrous
Seal	Viton
O Ring	Viton
Coalescing Medium	Copper
Max. Working Pressure	150 psig
Max. Operating Temperature	270°F

Notes:

Model	Unit	VDR100	VDR125	VDR150	VDR200
Pipe Size	inch	1	1-1/4	1-1/2	2
D	inch	3-1/8	3-1/8	3-1/8	4
H2	inch	14	14	14	17-1/4
h2	inch	6-3/4	6-3/4	6-3/4	7-3/4
L	inch	8-5/8	8-5/8	8-5/8	10-1/8
e	Inch	1/2	1/2	1/2	1/2
Weight (lbs)	FT/SW	9.0	9.0	9.0	14.5
Rec. Flow	GPM	10	15	30	40

FT – Female Threads / SW – Sweat Connection