

SPIROVENT QUAD®

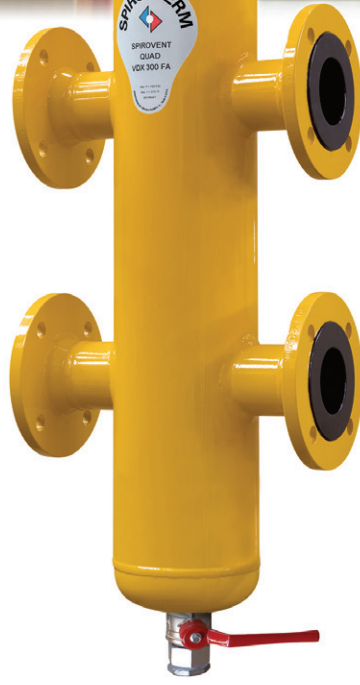
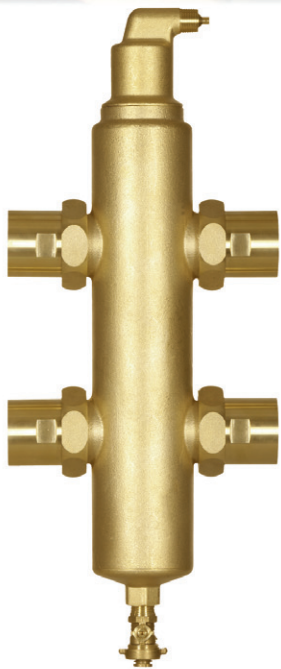

MICROBUBBLE™ SEPARATORS
DIRT SEPARATORS
LOW LOSS HEADERS
HYDRAULIC SEPARATORS

SPIROTHERM

THE ULTIMATE IN DISTRIBUTION EFFICIENCY

AIR- AND DIRT-FREE SYSTEM WATER THROUGH A SINGLE UNIT, PLUS HYDRAULIC SEPARATION IN A LOW LOSS HEADER.

The life and efficiency of a heating or cooling system are greatly dependent on the quality of the system water. Air and dirt problems cause frequent breakdowns and increased customer complaints. Corrosion, cavitation, and component wear are consequences of dirty, air-saturated water. Recurring problems and increased maintenance result in unnecessary costs and dissatisfied owners.

Many systems now have the need for hydraulic balance due to separate circuits with variable speed pumps or the need for chiller and boiler loops. Combining all these features in a low loss header would save time and reduce installation costs.

There is a solution!

A system without air and dirt is possible, combined with hydraulic balance and all manufactured within a low loss header. There is a unique four-purpose device that will remove air and dirt down to the smallest particle, keeping the system free from air and dirt, permanently.

It includes connections for two separate circuits, requires little maintenance, and works without strainers or filters. Less maintenance, fewer costs, satisfied owners!

The name:

SPIROVENT QUAD

QUAD BRASS

1"-2"

Threaded
or Sweat

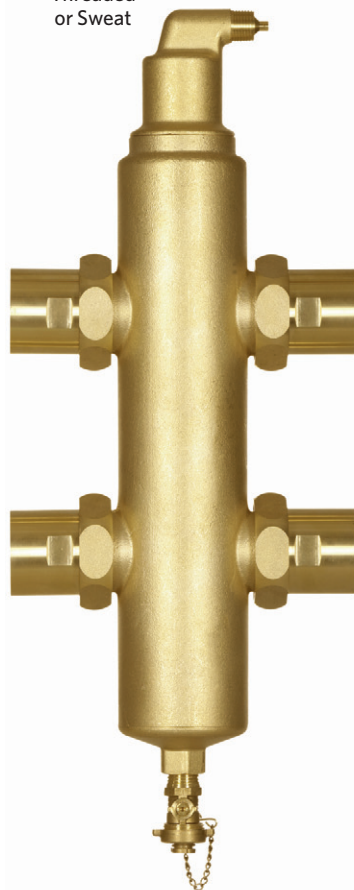

QUAD STEEL

2"-12"

Threaded or Flanged
ASME through 4"

Flanged
ASME 5"-12"



THE ULTIMATE IN DISTRIBUTION EFFICIENCY

THE KEY DIFFERENCE

Unlike other products which are empty vessels or include only a baffle plate, the Spirovent Quad® combines the features and benefits of the industry-leading Spirovent® air eliminator along with the Spirotrap® dirt separator.

The coalescing element and dirt separation medium completely fill the internal volume of the vessel, providing unsurpassed efficiency. Connections have been engineered and placed to allow for the ultimate in hydraulic balance.

The unique construction of this combined unit allows for the removal of both entrained air and dirt particles. The patented Spirotube®, the core of the Spirovent Quad, creates a low velocity area in the Spirovent core that allows removal of 100% of the free air, 100% of the entrained air, and up to 99.6% of the dissolved air in the upper chamber. The lower chamber provides for removal of all particles 30 micron and larger within 100 passes. Dirt and sediment sink to the bottom of the unit and collect in the dirt chamber, eliminating any blockage concerns. The dirt can be flushed through the drain while the system remains fully operational, and the large collection chamber ensures infrequent flushing.

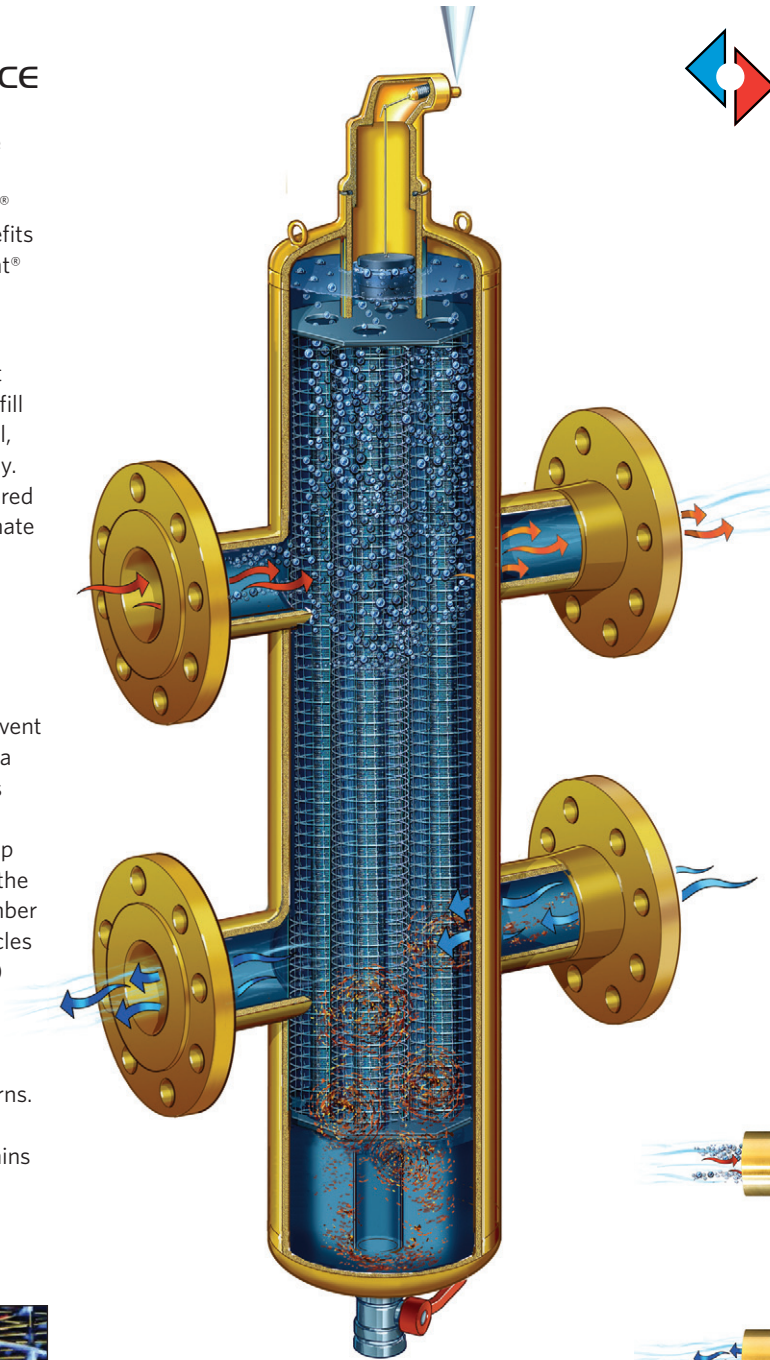
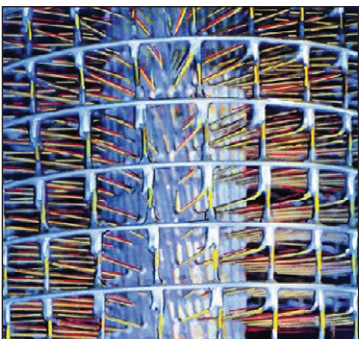

ADVANTAGES TO THE INSTALLER AND THE END-USER

- Integral brass, float-operated venting mechanism with Viton® seal
- No bypass, isolating valves or replacement filters to clog and reduce flow
- Two full-flow operating functions plus hydraulic balance in a low loss header
- Dirt can be flushed while the system is in full operation.
- Quiet operation
- Minimum pressure drop; always constant
- Increased component life
- Reduced oxygen-based corrosion and pump cavitation
- Provides optimum heat transfer

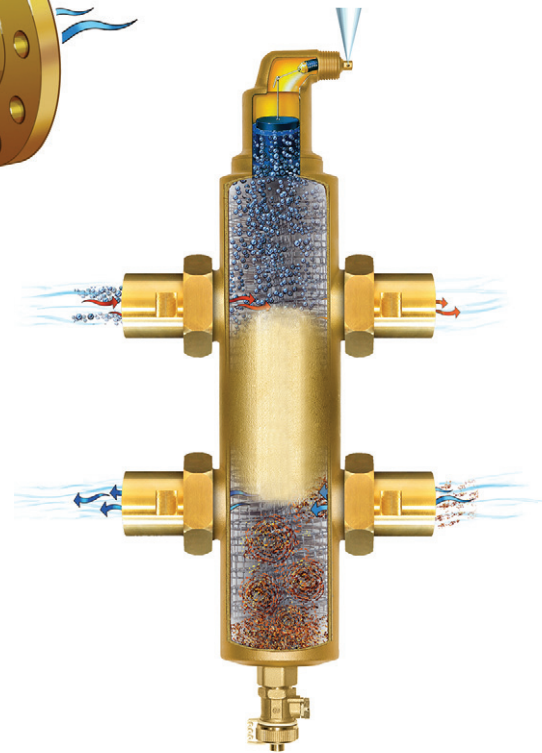

THE ULTIMATE IN DISTRIBUTION EFFICIENCY

SPIROVENT QUAD®

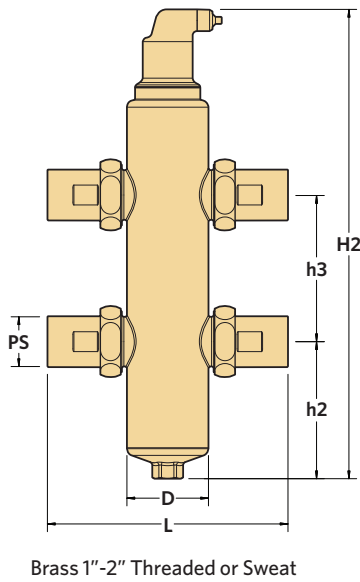

Brass 1"-2" Threaded or Sweat

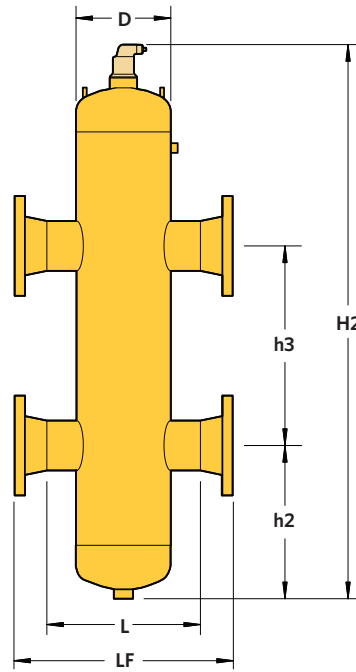

Steel 2"-12" Threaded or Flanged

HOW EXACTLY DOES A HYDRAULIC SEPARATOR WORK?

A hydraulic separator balances the differences in volumetric flow between a primary circuit (supply = Q_p) and a secondary circuit (demand = Q_s). Three operating situations can occur if a hydraulic separator is installed in a system, as shown below.

Cooling

Heating

Situation 1: $Q_p = Q_s$ $\Delta T_p = \Delta T_s$ $T_2 = T_4$

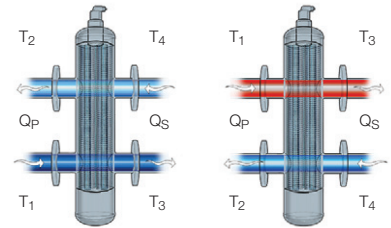

In this rare situation, supply and demand are exactly equal. This is the ideal situation in which the hydraulic separator operates primarily as a high efficiency air eliminator and dirt separator.

Situation 2: $Q_p < Q_s$ $\Delta T_p > \Delta T_s$ $T_2 = T_4$

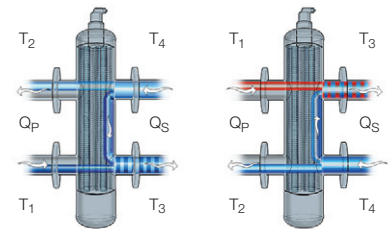

In this situation, demand is greater than supply. Some of the colder return water will join the supply, as a result of which it will take longer for the rooms to reach their set temperature. Where possible, the power of the boiler or chiller will then be increased.

Situation 3: $Q_p > Q_s$ $\Delta T_p < \Delta T_s$ $T_2 > T_4$

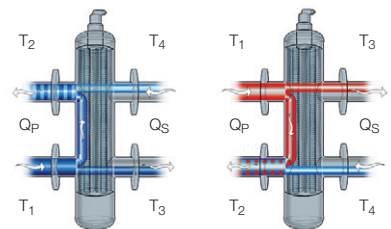

In the third situation, supply is greater than demand. Some of the warmer supply water will now join the return water, resulting in a decrease in the efficiency of the boiler or chiller. Where possible, the power will be modulated downwards.

TECHNICAL SPECIFICATIONS

STEEL		VDX200	VDX250	VDX300	VDX400	VDX500	VDX600	VDX800	VDX1000	VDX1200
Pipe Size	Inch	2	2½	3	4	5	6	8	10	12
D	inch	6.6	6.6	8.6	8.6	12.8	12.8	16.0	20.0	24.0
H2	inch	32.0	36.0	39.0	50.0	61.0	70.0	91.0	113.0	133.0
h2	inch	9.4	9.9	10.6	13.8	17.4	19.9	26.6	32.9	39.2
h3	inch	9.5	12.0	14.0	18.0	22.0	26.0	34.0	42.0	50.0
L*	inch	12.0	12.0	15.0	15.0	—	—	—	—	—
LF	inch	15.0	15.0	20.0	20.0	26.0	26.0	32.0	36.0	42.0
Weight (lbs)	MT	56	64	106	137	—	—	—	—	—
	FA	80	96	146	197	273	323	622	978	1747
Recom. Flow**	GPM	45	70	95	170	260	375	625	950	1400
BRASS		VDX100	VDX125	VDX150	VDX200					
Pipe Size	Inch	1	1¼	1½	2					
D	inch	3¼	3¼	3¼	4					
H2	inch	20¼	20¼	20¼	30¼					
h2	inch	7¾	7¾	7¾	8¼					
h3	inch	5¾	5¾	5¾	10¼					
L	inch	8⅝	8⅝	8⅝	10⅝					
Weight (lbs)	FT/SW	13.2	14.3	15.4	26.4					
Recom. Flow**	GPM	10	15	30	40					

Brass, 1" through 2" : Brass body, copper medium, brass vent head, brass blow down valve.
"FT" - Female Threads / "SW" - Sweat Connections

Steel, 2" through 12" : Steel body, copper medium, brass vent head, brass blow down valve.
"MT" - Male Threads (2" through 4") / "FA" - Flanged ASME (2" through 12")

* "L" Dimension for male threaded "MT" models only.

** Recommended flow based on 4 ft./sec. Entering Velocity

All models designed as standard for 150 psig and 270 F°

Larger sizes available — consult local sales office