

SPIROTHERM®

SPIROVENT® INSTALLATION and OPERATION INSTRUCTIONS AIR ELIMINATOR MODELS VSR/VHR Through 12"

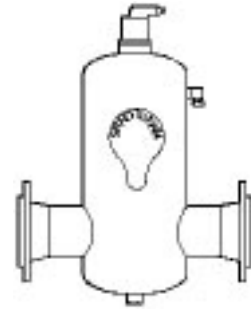

This safety alert symbol will be used to draw your attention to safety related instructions. When used, this symbol means Attention! Your safety is involved! Become Alert! Failure to follow these instructions could result in a safety hazard!

INSTALLATION INSTRUCTIONS

The Spirovent Air Eliminator should be installed at the point of lowest solubility in the system: that being where the temperature is the highest (i.e. after the boiler and/or heat exchanger or before the chiller) and the pressure is the lowest (i.e. before the pump suction), as pictured in Figures 1 and 2 below. As with all hydronic system piping it is recommended to have the expansion tank connection to the system on the suction side of the pump or circulator.

Units must be mounted in a straight run of horizontal piping in a perfectly upright position to allow the vent to operate freely. The piping normally supports the weight of the Spirovent units up to and including 12". Support legs recommended for units 14" and larger. "X" pipe diameters of straight run before and after the unit are not required.

The flow may be directed to either side of the unit. There is NO directional arrow. Either connection may be used for inlet or outlet.

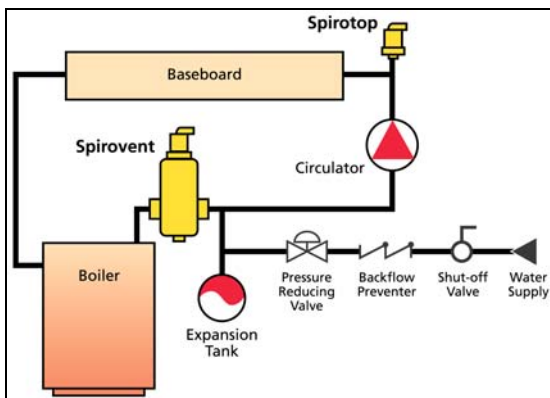

Figure 1 (Heating System)

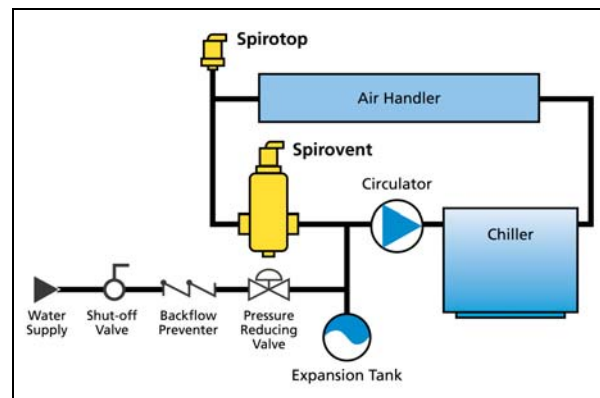



Figure 2 (Chilled Water System)

The threaded connection at the air vent outlet has been provided as a convenience for those wanting to pressure test the system with air prior to filling.

1. To test, install a 1/2" pipe cap before filling and remove the cap once testing is complete. **During operation, this threaded connection should be free of any piping connection with the unit in service to allow the free flow of air and gases.** It may be piped to another location if left open, however, the risk then exists for blockages, which will impede the product's performance.

CAUTION! Do not attempt to turn the venting port, as that will damage and/or destroy the venting mechanism.

The side tap valve on the side of the Spirovent Senior unit is provided to skim off debris that may collect and float on the surface of the water. The valve may be opened during system fill to allow for faster filling of the vessel. A hose may be used to direct air and water away from personnel and/or other equipment. Close valve once water is present.

 **WARNING! Water temperatures above 100°F can be very hazardous. Keep body away from valve while open. Failure to follow these instructions may cause serious bodily injury or property damage.**

SERVICE INSTRUCTIONS

The Spirovent does not normally require maintenance and includes no moving parts other than those in the vent head itself.

 **WARNING! System fluid under pressure can be very hazardous. Before removing the vent head for inspection, reduce system pressure to zero, or isolate the Spirovent from the system. Allow the system to cool to below 100°F. Failure to follow these instructions may cause serious bodily injury or property damage.**

Periodic blowdown through the bottom connection may be required should any dirt or sediment collect in the bottom of the vessel. This is system dependent and may or not be necessary subject to other installed components such as sand filters or strainers. A container should be used to catch any debris.

 **WARNING! Water temperatures above 100°F can be very hazardous. Keep body away from connection while open. Failure to follow these instructions may cause serious bodily injury or property damage.**

SPIROTHERM
A Spiro Enterprises Company

Spirotherm, Inc.
25 N. Brandon Drive
Glendale Heights, IL 60139

630-307-2662
Fax: 630-307-3773

Website: www.spirotherm.com
E-mail: info@spirotherm.com

© 2005 Spirotherm, Inc.

AirIOM-B